

Product Overview

The **μFalcon-RX** is an essential element in delivering on the promise of 5G. Through high capacity, low latency transport and high precision synchronization, the **μFalcon-RX** enables 5G RAN operation at its optimal capacity, on both telecom and enterprise environments.

The **μFalcon-RX** combines the best of breed of the Transport and Timing worlds, in a single powerful package. Both elements are critical for 5G fronthaul deployments, along with support for the latest O-RAN architectures and recommendations.

The **μFalcon-RX**'s Timing toolbox includes a complete set of capabilities, including GNSS based PTP GM/BC/TC/OC (sub nanosecond accuracy, Class C/D performance), along with robust SyncE and other sync interfaces. The system's timing is orchestrated via Fibrolan's user friendly SyncCenter.

The **μFalcon-RX** series is equipped with a total of 6xSFP+ and 2xSFP28 ports, with configurable port setup for up to 110Gbps Full Duplex. All ports can operate at full wire speed, at any packet size (including Jumbo frames).

The **μFalcon-RX** offers advanced Quality of Service (QoS) features including classification and mapping based on layer 1 through layer 4 attributes, port and queue policing and shaping, with highly flexible scheduling schemes.

Support for Time Sensitive Networks (TSN) makes the **μFalcon-RX** an even greater fit for fronthaul, as well as industrial environments (Industry 4.0, IIoT), where 5G infrastructure serves the automation of factories.

The **μFalcon-RX** fully supports O-RAN LLS-C1 through C4 configuration including the

- LTE/5G xHaul Transport and Timing switch
- Integrated PTP Grandmaster
- Compatible with O-RAN architectures
- High capacity, low latency
- Extensive Sync and Timing with SyncE and PTP (PTRC/GM, BC, TC)
- Sub nanosecond timestamping, Class C/D performance
- Time Sensitive Networking support
- Based on 4th generation Falcon architecture
- Advanced QoS and service level traffic management
- Advanced OAM and management capabilities
- Multiple protection mechanisms for link, path, and ring service resilience
- Compact, low power, fan-less design



forwarding of C/U-plane eCPRI packets and S/M planes for management and synchronization.

Multiple protection schemes help cover any deployment topology (linear, star, ring) and deliver the reliability required for critical infrastructure such as 5G. In addition, L3 forwarding is supported (static; dynamic routing in future SW releases).

The system implements effective OAM tools, for monitoring, alarming, analysis and troubleshooting of the system and the forwarding plane as well as the synchronization plane.

The is housed in a highly compact, half-19", 1U chassis (150mm deep only), implements a fan-less design, and has an integrated internal, dual feed DC power supply.

Technical Specifications

Interfaces & Indicators

- Ethernet:
 - 6 x 1/2.5/10G (SFP+)
 - 2 x 1/2.5/10/25G (SFP28)
- Supported SFP/SFP+: MM, SM, SFS, xWDM, Copper
- Sync & Timing:
 - All optical ports support PTP, SyncE and NTP
 - GNSS antenna in (SMA, active, 5VDC)
 - 2 x external 1PPS/10MHz (SMA)
- Management (OOB):
 - 1 x 10/100/1000BaseT (RJ45)
 - 1 x USB (console)
- LEDs
 - Link/Activity (per port)
 - Sync
 - GNSS
 - CPU
 - Power

Architecture & Forwarding

- Hybrid (ASIC-FPGA) HW architecture
- L2 forwarding (802.1D MAC bridging)
- Flow-based forwarding
- Performance: wire-speed, on all ports, all frame sizes
- Switching fabric: 220Gbps (110Gbps/FDX), non-blocking
- MTU: 10K bytes
- MAC table: 32K addresses
- VLANs: 4K concurrent
- Provider bridging: 802.1ad (Q-in-Q)
- Private VLANs
- L1-L4 ACLs
- Multicast:
 - IGMPv3 snooping
 - MLD snooping
 - Up to 8K MC groups
- Layer 3:
 - Static routes
 - IPv4/IPv6
 - DHCP (client, server, relay)
- Time Sensitive Networking

PTP/IEEE1588

- Functions:
 - Grandmaster (PRTC)
 - Boundary Clock (Class C/D)
 - Ordinary Clock (M/S)
 - Transparent Clock (Class C/D)
- Profiles supported:
 - Telecom Frequency (G.8265.1)
 - Telecom Phase (G.8275.1, G.8275.2)
 - Default (IEEE1588)
 - 802.1AS
 - Custom
- Modes supported:
 - 1 and 2 step
 - L2 Multicast
 - L3/UDP Unicast/Multicast
 - Mixed transport modes
 - E2E and P2P delay
 - VLAN tagging
- Slave capacity:
 - Up to 128 Unicast @ full packet rate
 - Support for max packet rates for: Announce, Sync and Del.Req/Del.Resp messages
- HW timestamping: <1nsec resolution

Other Timing Services/Features

- Synchronous Ethernet (SyncE):
 - G.8261, G.8262
 - ESMC (G.8264)
- GNSS:
 - 32 channels
 - Multi-constellation : GPS, GLONASS, Galileo, Beidou, QZSS
- Support O-RAN configurations LLS-C1/C2/C3/C4
- SyncCenter
- NTP
 - Client
 - Server
- External Sync:
 - Input/output
 - 1PPS/10MHz
- Local clock:
 - Built-in Stratum 3E clock

Quality of Service

- Classification based on L1-L4 information
- Ingress policing per port/queue
- Hierarchical shaping and scheduling
- Priority based flow control (802.1Qbb)
- Scheduling: Strict, DWRR, hybrid
- 4 drop precedence levels
- WRED and tail drop for CA
- P-bit and DSCP remarking
- Storm control: UC, MC, BC
- QoS Control Lists

Protection

- Link aggregation: static or LACP
- Loop protection
- Linear protection: G.8031
- Ring protection: G.8032v2
- Spanning tree: STP, RSTP, MSTP

OAM & Diagnostics

- IEEE802.3ah Link OAM
- IEEE802.1ag CFM
- Ping (IPv4/v6)
- Traceroute (Ipv4/v6)
- Throughput metering
- SFP diagnostics (SFF-8472)
- Traffic mirroring and remote mirroring
- sFlow

Management

- Interfaces:
 - CLI: Console, Telnet, SSH
 - SNMP: v1/v2c/v3, extensive MIBs
 - Web: HTTP/HTTPS
 - Management VLAN
 - IPv6 management
- Authentication:
 - RADIUS, TACACS+
 - Multiple local users
 - User access levels (15)
 - Management ACLs
 - 802.1x (port/MAC based)
- DHCP client, relay, server, snooping
- Link discovery: LLDP, LLDP-MED, CDP ware
- CPU sub-system:
 - Dual-core, @1GHz, ARM
 - 1GB DDR, 4GB flash memory
- Operations:
 - Remote System Update (TFTP or Web)
 - Configuration upload/download (TFTP or Web)
 - Text based config files
- Alarms:
 - SNMP traps
 - Syslog (internal and remote server)
 - CLI events
- Remote temperature reading & alarm
- Per port and queue detailed statistics
- RMON

Power & Environmental

- Power Supply:
 - Internal power supply: 20-60VDC, dual feed
 - AC adapter option (FPA40)
- Power consumption:
 - Maximum: <25W; typical: <20W
- Operating temperature:
 - Standard: -10°C ÷ +50°C (14°F ÷ 122°F)
 - Extended: -40°C ÷ +65°C (-40°F ÷ 149°F) (optional)
- Storage temperature: -40°C ÷ +80°C (-40°F ÷ 176°F)
- Humidity: 10-90%, non-condensing

Physical

- Dimensions (HxWxD):
 - 44x221x150mm (1.73x8.70x5.90 inch)
- Mounting:
 - Desktop
 - Rack
 - Wall
- Weight: ~0.8Kg (1.76 lb)
- Accessories:
 - Power cable
 - USB cable (console)
 - Rack mounting kit (optional)

Regulatory & Compliance

- Safety:
 - IEC EN60950-1
- CE
- RoHS
- EMC:
 - FCC CFR 47 part 15, subpart B, Class A
 - EN 300 386 V1.3.3: 05

Typical Application: Private LTE/5G/CBRS

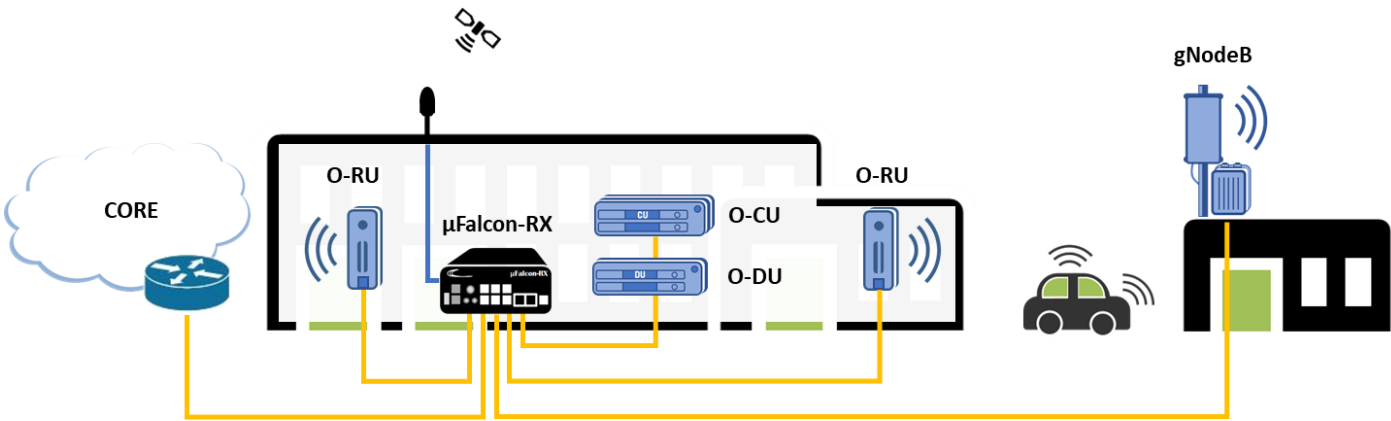

Ordering Information

Model	P/N	Description
µFalcon-RX/206/G/D	7162	Timing Aware Compact Edge xHaul Switch, 6x10G (SFP+), 2x25G (SFP28) ports, Advanced Timing spec w/ GNSS Rx, internal DC (20-60VDC) dual feed power supply
FPA40	7108	AC (100-240V) to DC (48V) power adapter, 40W

Specifications are subject to change w/o prior notice

We've got Timing for you!



Intl. Headquarters
Fibrolan Ltd.
Tel: +972-4-959-1717
Fax: +972-4-959-1718
info@fibrolan.com
www.fibrolan.com

North America
Fibrolan Inc.
Tel: +1-201-843-1626
Fax: +1-201-843-1628
us.info@fibrolan.com
www.fibrolan.com

Central-Eastern Europe
Fibrolan CEE GmbH.
Tel: +43-2253-21188-0
Fax: +43-2253-21188-99
office@fibrolan.at
www.fibrolan.at